

GAMMA & BROSS
SALON AND SPA DESIGN
EVERLASTING BEAUTY

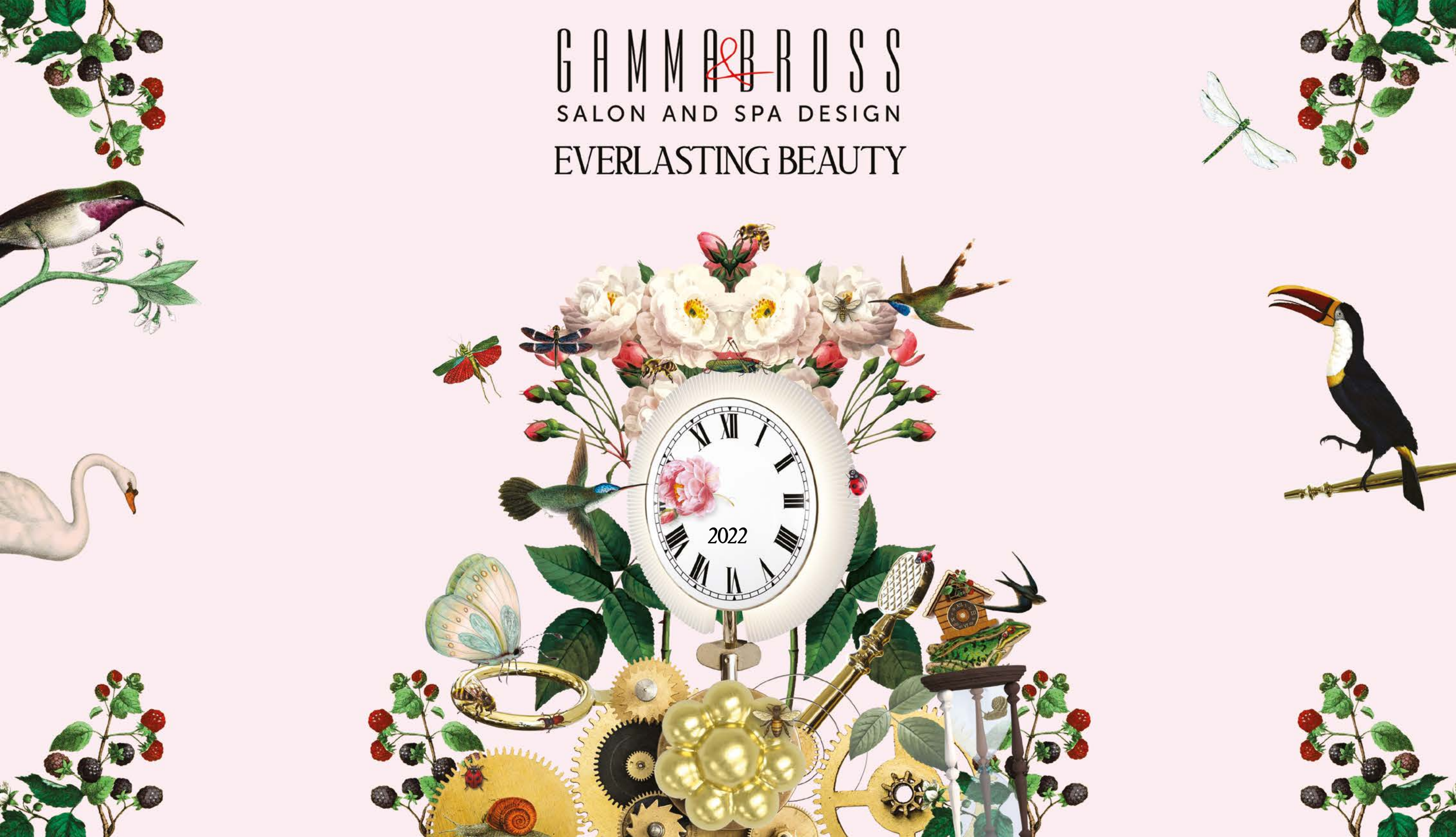

GAMMA & BROSS
SALON AND SPA DESIGN



MG BROSS - THE LUXURY COLLECTIONS.....9

LADY JANE COLLECTION by Marcel Wanders Studio.....11

COLLEZIONE PRIVATA by Marcel Wanders Studio.....49

DRESSING BEAUTY by Aldo Coppola.....73

ECHOES COLLECTION by Anton Kobrinetz.....89

NUTOPIA by Karim Rashid107

DESIGN by F.A. Porsche.....121



GAMMA STATE OF THE ART - TRANSITIONAL DESIGN.....137

STYLING STATIONS / POSTI LAVORO.....139

STYLING CHAIRS / POLTRONE ACCONCIATURA.....163

BASES / BASI.....182

SHAMPOO STATIONS / LAVAGGI.....185

WAITING AREA SOFAS / DIVANI ATTESA.....197

RECEPTION DESKS / BANCHI CASSA RECEPTION.....207

CABINET SHOP.....219

ACCESSORIES / ACCESSORI.....234

BARBER.....260



GAMMASTORE - IL DESIGN ACCESSIBILE.....271

STYLING STATIONS / POSTI LAVORO.....273

STYLING CHAIRS / POLTRONE ACCONCIATURA.....297

SHAMPOO STATIONS / LAVAGGI.....317

WAITING AREA SOFAS / DIVANI ATTESA.....340

SALON RECEPTION DESKS / BANCHI CASSA RECEPTION.....349

ACCESSORIES / ACCESSORI.....361



SPALAGIC - THE ARCHITECTURE OF WELLNESS.....369

PEDICURE.....370

PEDICURE ACCESSORIES / ACCESSORI PEDICURE.....376

MASSAGE TABLES / LETTINI MASSAGGIO.....378

MANICURE.....383

BEAUTY FURNITURE / MOBILI CABINA.....386

DISPLAYS / ESPOSITORI.....387

RELAX LOUNGE CHAIRS / POLTRONE RELAX.....388

MANICURE CHAIRS / POLTRONE MANICURE.....391



SAMPLES BOOK / RIVESTIMENTI.....393

FIREPROOF LIST / TABELLA IGNIFUGICITÀ403



MG
BROSS
DESIGN
&
DESIGN

The Luxury Collections

MG Bross presenta gli arredi più esclusivi per parrucchieri e saloni di bellezza, progettati dai più famosi designer e studi di design internazionali. Offre una selezione di posti lavoro in materiali pregiati, lavatesta con massaggio e cromoterapia, poltrone dal design unico, e molti altri prodotti per saloni di successo. Il brand nasce nel 1995, quando, anticipando i trend, lancia la collezione *Minimal Zen*. Da allora, ogni anno presenta nuovi prodotti coinvolgendo nuovi designer, utilizzando nuovi materiali, sperimentando soluzioni innovative.

MG Bross presents the most exclusive furniture for beauty and hair salons, designed by world famous international designers. The brand offers a selection of styling stations in luxury materials, shampoo stations with massage and chromatherapy, salon chairs with unique designs, and many other products to make every salon stand out. The brand is born in 1995 with the launch of the *Minimal Zen* Collection. Since then, every year new products are developed involving new designers, using new materials, experimenting innovative solutions.



lady Jane

by m̄rcel w̄anders

“Poetica e funzionale, la Jane Collection rispetta requisiti tecnici specifici, include i migliori materiali, e risponde ergonomicamente al comfort sia del cliente che dello stilista, che lavora tutto il giorno. Con questa collezione, abbiamo creato pezzi versatili che si completano a vicenda e vanno a creare un ambiente armonico, indipendente dal salone in cui saranno inseriti.” dice Gabriele Chiave, Creative Director.

La Jane Collection by Marcel Wanders Studio per Gamma & Bross porta il lusso di una spa nel salone professionale.

Le curve poetiche, le forme precise, i dettagli lussuosi e gli accessori versatili della collezione caratterizzano il design di questi prodotti, che possono trasformare ogni spazio in un ambiente elegante ed accogliente.

Realizzati per offrire una funzionalità in grado di elevare lo spirito, la collezione porta una brezza fresca nel settore dell’acconciatura professionale, mostrando un perfetto bilanciamento fra utilità ed estetica.

“Abbiamo creato questa collezione per permettere ad ogni salone di trasformarsi in una destinazione. Il design dei prodotti riflette il corpo umano in uno stato di riposo, permettendo ai clienti di scoprire la bellezza, mentre ci si prende cura della loro bellezza”, dice Marcel Wanders, Creative Director.

Mentre questa collezione impressiona magnificamente nel suo insieme, ogni pezzo emerge come simbolo di bellezza individuale.

“Poetic and functional, the Jane Collection adheres to specific technical requirements, includes durable materials and ergonomically responds both to the comfort of the customer and the hair stylist, who works all day. With this collection, we have created versatile pieces that complement each other and provide an harmonic environment, independently of the salon they will live in.” says Creative Director Gabriele Chiave.

The Marcel Wanders Studio’s Jane Collection for Gamma & Bross brings spa-like luxury to professional hair salons.

Highlighting the design of these pieces are the collection’s poetic curves, precise silhouettes, rich details and versatile accessories that can transform any space into an elegant and welcoming interior.

Made to function while uplifting the human spirit, the collection is a fresh breeze in the field of professional equipment, demonstrating a beautiful tango between purpose and aesthetics.

“We created this collection to enable any salon to be transformed into a destination. The design of the pieces reflects the human body at rest, allowing guests to discover beauty while being made beautiful themselves,” said Marcel Wanders.

While this collection impacts beautifully as a whole, each piece also stands alone as an individual throne of beauty.

*lady
Jane*



by **mārcel wānders**



LADY JANE COLLAR



BALLET 2 COLLAR



BALLET 4 COLLAR



BALLET 2 RING



BALLET 4 RING



LADY JANE RING



LADY JANE RING WALL



KATHERINE COLLAR



KATHERINE RING



KATHERINE COLLAR WALL



KATHERINE RING WALL



LADY JANE COLLAR WALL



BALLET SPECCHIO COLLAR WALL



BALLET SPECCHIO RING WALL



QUEEN MARY



QUEEN MARY



QUEEN MARY



QUEEN MARY



QUEEN MARY



QUEEN MARY



GUILDFORDESK 200



GUILDFORDESK 150



GUILDFORDESK 100



GUILDFORDESK 100



TUDOR WASH



BALLET BENCH

marcel wanders[©]

Collezione privata



Le creazioni di Marcel Wanders Studio combinano eleganza e sofisticazione ad un tocco di fantasia ludica che contraddistingue sempre le opere di questo geniale designer.

“La collezione che ho disegnato per Gamma & Bross si ispira ai saloni di bellezza del passato, dove le donne passavano molto tempo per farsi belle. La collezione è intitolata “Collezione Privata”. L’obiettivo del mio progetto era quello di trasformare il tempo trascorso nel salone in una indimenticabile esperienza personale ed intima.

Infine, credo che così come i gioielli sono lo strumento di seduzione della donna, tutti gli oggetti della collezione, pur essendo fondamentalmente delle attrezzature tecniche, sono soprattutto dei preziosi elementi di arredo”.
M. Wanders.

Marcel Wanders Studio designs reflect modern and elegant sophistication, with a touch of his playful fantasy.

“The collection I have designed for Gamma & Bross is inspired by the salon experience of the past, where women would spend time beautifying themselves. The collection is titled “Collezione Privata” (Private Collection) and with the design I have sought to make the salon experience beautiful, personal and intimate.

Above all, I believe women’s tools should be jewels, so all elements of the collection while technical equipment is first and foremost beautiful pieces of furniture.” M. Wanders.

Collezione privata



by **mārcel wānders**



NABUCCO



NABUCCO LED



NABUCCO WALL



OTELLO



OTELLO INFINITE 3P



OTELLO INFINITE 2P



AIDA



AIDA





AIDA MAKE UP



AIDA MAKE UP





AIDA WOOD



VA PENSIERO WOOD



VA PENSIERO



VA PENSIERO



ALZIRA CURVA



ALZIRA



OBERTO



AROLDO



LIBIAM



RIGOLETTO



MENSOLA MW



FALSTAFF

“Dressing Beauty” by

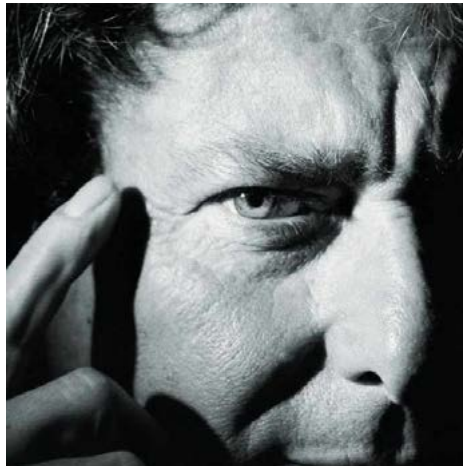

Nel 1965 Aldo Coppola apre il suo primo Atelier in Via Manzoni in centro a Milano, e inizia a collaborare per i Set Fotografici delle più importanti testate italiane ed internazionali. Realizza anche acconciature all'avanguardia per le sfilate di moda con gli stilisti più prestigiosi (Giorgio Armani, Versace, Gianfranco Ferré, Valentino e molti altri). L'azienda si sviluppa con l'apertura e il posizionamento in aree strategiche di nuovi Atelier diretti, con l'istituzione della prima agenzia di freelancer d'Italia dedicata alla moda, alle campagne stampa, tv, fashion show, fino alla divulgazione della formula franchising Aldo Coppola, alla creazione del progetto Accademia, alla distribuzione di prodotti e accessori a marchio Aldo Coppola.

Oggi l'azienda si diversifica in vari brand, come Go Coppola e Shatush, divulgando lo sviluppo anche in campo internazionale.

Gamma & Bross presenta la nuova linea “Dressing Beauty” by Aldo Coppola, un nuovo modello di Design che rivoluziona il modo di concepire e vivere il salone, che cambia d'abito per assecondare stagioni, mode, stati d'animo e ricordi. L'arredo, che si può “vestire e svestire”, può mutare a piacere scegliendo il Design dalla cartella tessuti. Per un look in grado di rinnovarsi e stupire sempre.

In 1965 Aldo opened his first salon on Via Manzoni in Downtown Milan and began working as a Hair Stylist for the photo shoots of top Italian and international magazines. He also created avant-garde Hairstyles for the Fashion Shows of some of the world's most famous designers (Giorgio Armani, Versace, Gianfranco Ferré, Valentino, and many more). The company grew, opening new directly-owned salons in strategic urban areas, establishing the first Italian freelance hair stylist and makeup artist agency for fashion shows, advertising campaigns, magazines and TV, promoting the Aldo Coppola franchising formula, creating the Academy project, and selling Aldo Coppola products and accessories. Today the company has diversified, adding new brands such as Go Coppola and Shatush and expanding on an international level.

Gamma & Bross presents the new “Dressing Beauty” collection by Aldo Coppola. This newly designed concept revolutionizes the way of conceiving a living salon, which changes clothes to suit seasons, fashions, moods and memories. For a look that can always amaze and be renewed, the furniture, which you can “dress and undress”, can change at will by choosing the Design from the fabric folder.

“Dressing Beauty”
by

ALDO
COPPOLA



MISS BEAUTY WALL



MISS BEAUTY CENTRAL



MISS BEAUTY ECO WALL



MISS BEAUTY ECO CENTRAL



MISS BEAUTY LITE WALL BIG WHITE



MISS BEAUTY LITE CENTRAL



PETAL



BEAUTY FLOWER



BEAUTY FLOWER



BEAUTY FLOWER 2P



BEAUTY DESK



HOURGLASS



ECHOES

C O L L E C T I O N

by Anton Kobrinetz

La collezione "ECHOES" firmata da Anton Paul Kobrinetz combina le più moderne tecnologie di produzione con il più alto standard artigianale Italiano per creare ancora una volta una linea di arredo destinata a diventare un classico del design.

La filosofia di Gamma & Bross nasce dall'idea che il design è l'elemento chiave della sua identità. L'immagine di un'azienda si riflette attraverso il prodotto dove il design è l'elemento fondamentale del processo.

Gamma & Bross presenta "ECHOES" collection, una linea caratterizzata da un design senza tempo.

"L'obiettivo era di creare forme sensuali e superfici che emettono un'attrazione emozionale. Ogni oggetto è disegnato nel linguaggio di forme organiche avvolte con materiali sintetici, trasformate quindi da solidi a liquidi e viceversa. Il punto è di ottenere un design duraturo, creando degli oggetti come simboli per comunicare un'immagine forte che evoca la memoria fisica che supera fashion e trend." A. Kobrinetz.

Their newest collection entitled "ECHOES", designed by Anton Paul Kobrinetz, combines the latest manufacturing technology with the highest standard of Italian craftsmanship, to create yet another line of furniture destined to become a Design classic.

The Gamma & Bross philosophy starts with the idea that design is the key element from which brands are built. The image of a company is defined by the visual communication of the goods it produces, and the instrumental element in this process is design.

Gamma & Bross is proud to present the "ECHOES" collection, setting its brand apart with timeless design.

"The collection draws inspiration from forms found in nature, particularly those that come from the sea, evoking antiquity at the same time a trace of the future, thus the name.

The aim is to create pure and sensual forms and surfaces that radiate emotional appeal. Each object is designed with the language of organic shapes enveloped in synthetic materials, transformed from solid to liquid and back again. The key is to achieve an enduring design, by creating the object as a symbol to communicate a strong image, that evokes a physical memory that goes beyond fashion and trend." A. Kobrinetz.



ECHOEES

C O L L E C T I O N



VENUS



VENUS



VENUS GOLD



VENUS BICOLOR



PROVOCATEUR BICOLOR

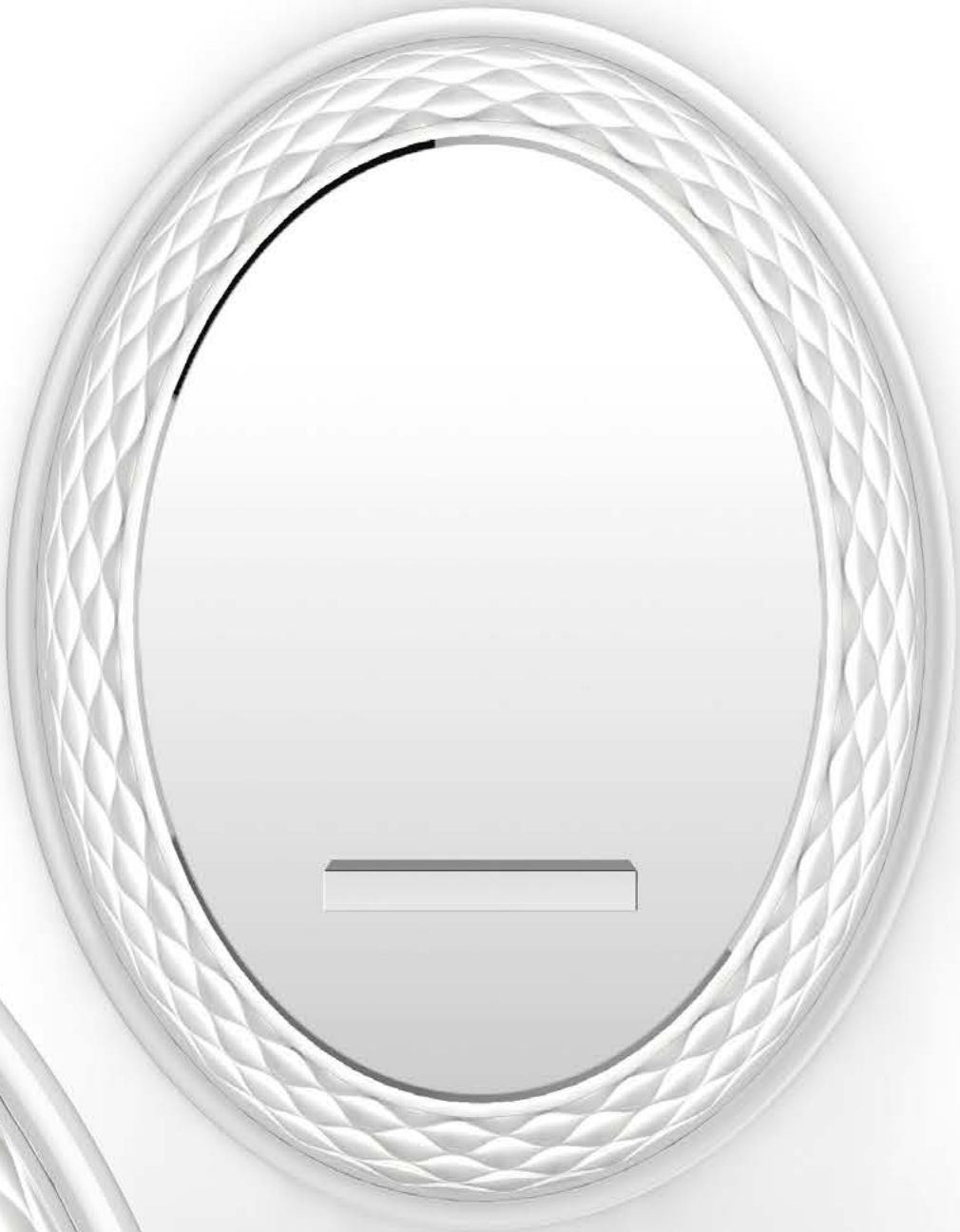
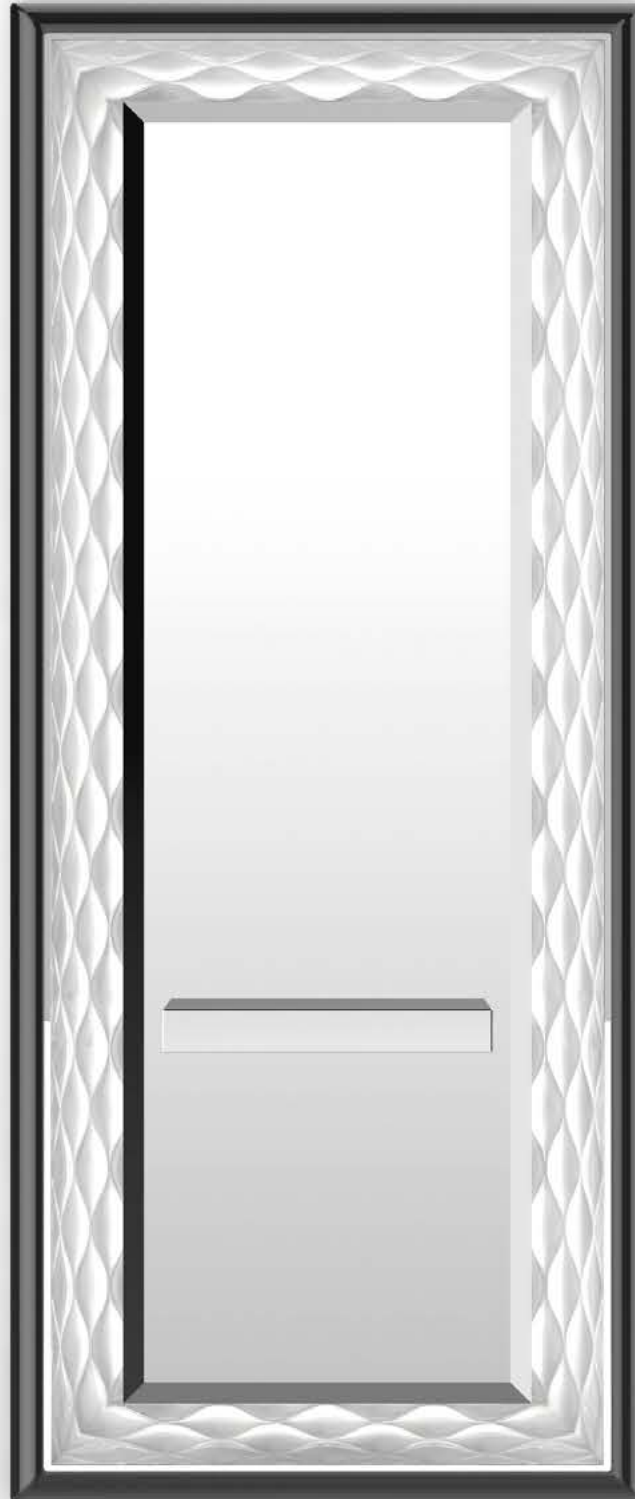

VENUS WALL



PROVOCATEUR GOLD

PROVOCATEUR BICOLOR



PEARL



PEARL



MUU MUU



MUU MUU

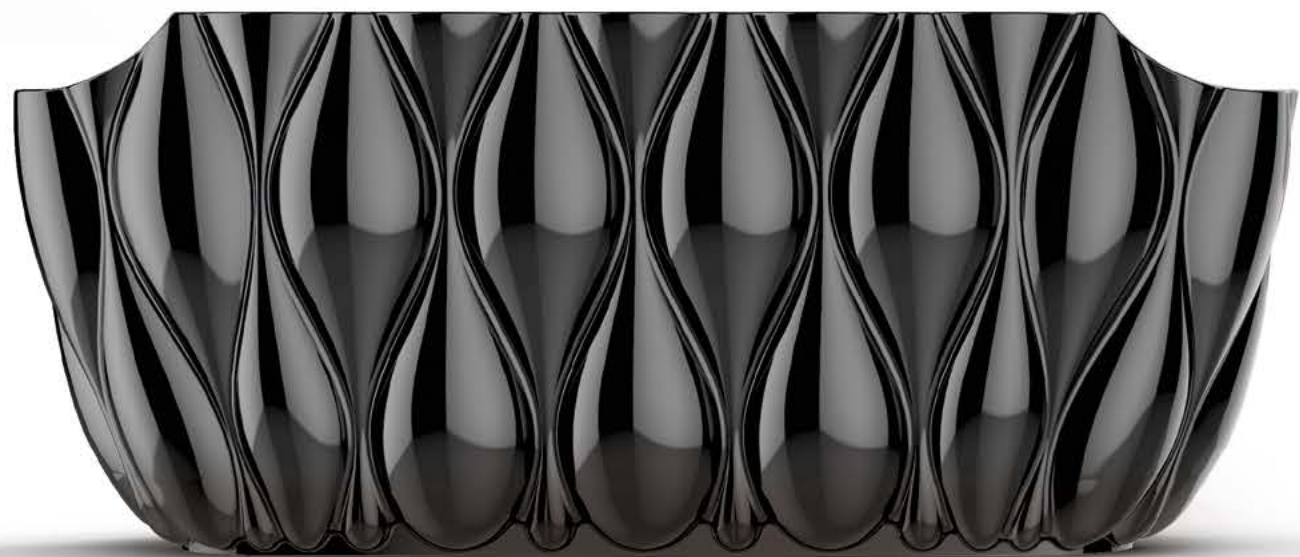

SEA URCHIN



SEA URCHIN



nutopia
Karim Rashid
Karim

Karim Rashid realizza la sua missione di modificare la percezione degli oggetti attraverso nuovi livelli sensoriali.

La collezione Nutopia è incentrata sul Teknowash, un sistema rivoluzionario che unisce il posto di lavaggio alla cromoterapia, al suono audio surround e al totale comfort del massaggio ad aria. Il processo di costruzione per la realizzazione della poltrona Sensual consiste in un avanzato sistema di produzione di scocca strutturale “seamless” che conferisce un alto livello di comfort. La postazione di lavoro Human ed il banco reception Komplete diventano corpi illuminanti e creano un effetto di fluttuante leggerezza.

Integrando alta tecnologia a forme scultoree, la collezione Nutopia di Karim Rashid rappresenta un'icona nel design dell'industria dei saloni di bellezza.

Karim Rashid applies his manifesto of changing the world with the concept of taking the user to a new level of sensation.

The Nutopia collection is centered around Teknowash, a revolutionary system that combines chromo-therapy and an audio surround sound in a total comfort shampoo unit. Rashid's Sensual chair is made using the most advanced molding process that creates both a structural frame as well as seamless comfort. Further, he uses illuminated forms in both the Human workstation as well as the Komplete desk to create a weightless floating effect.

Through the integration of high technology and sculptural forms, Rashid's Nutopia collection represents the design icons of the beauty industry.



nutopia
Karim Rashid
KARIM RASHID



HUMAN



HUMAN CENTRAL



SENSUAL



NUPED

SENSUAL



TEKNOWASH PLUS



TEKNOWASH PLUS



TEKNOWASH BASIC



KOMPLETE



NUPED

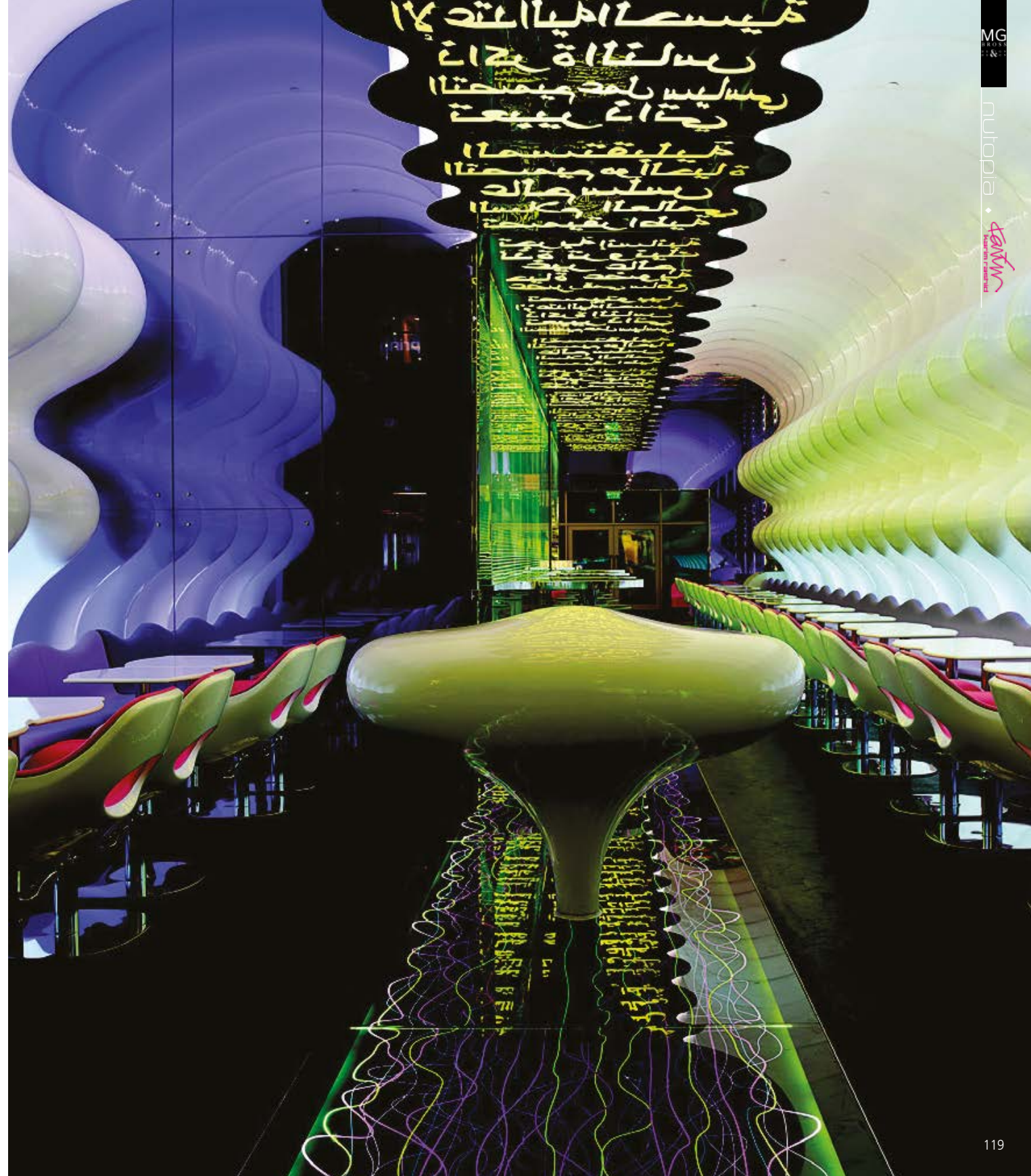

DESIGN by F.A. PORSCHE

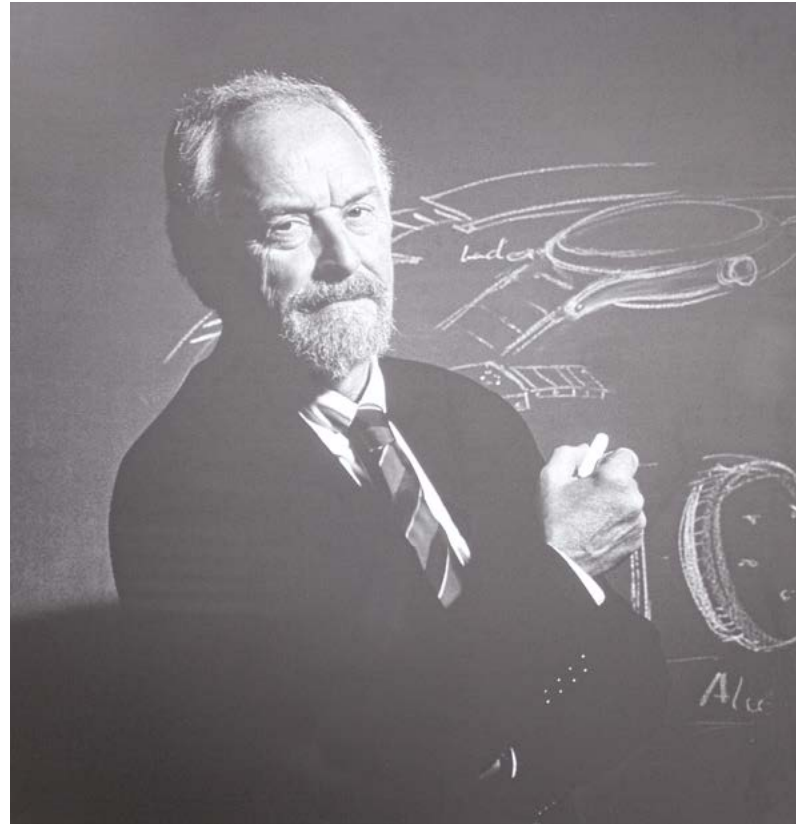

Lo studio è stato fondato a Stuttgart, in Germania, nel 1972. Il suo ideatore, Ferdinand Alexander Porsche è l'artefice della celebre vettura 911.

Proprio il suo grande successo mondiale è stato il volano della diffusione del marchio Porsche Design.

Questa tradizione prosegue ancora oggi, incentrata sull'efficienza delle forme e sulla qualità dei materiali. La gamma attuale propone una serie di prodotti esclusivi: moda in pelle, valigeria, accessori, scarpe moda, cronografi e utensili da cucina, occhiali da sole e la personalizzazione di dispositivi cellulari.

La filosofia di design di F.A. Porsche emerge chiaramente in questa collezione che combina materiali tecnologici al design minimale. L'approccio Porsche di sviluppo dei prodotti innovativi è caratterizzato da forme che sono parte integrante delle loro funzioni. La combinazione di design funzionale e minimale con le innovazioni tecnologiche è ciò che rende la collezione F.A. Porsche un classico senza tempo.

The Porsche Design Studio was opened in Stuttgart in 1972 by professor Ferdinand Alexander Porsche, the man who designed the Porsche 911, grandson of the Porsche founder.

The 911 quickly became the quintessential sports car and a design classic, along with many other products that professor F. A. Porsche designed: watches, glasses and writing utensils were created and marketed worldwide under the "Porsche Design" brand.

The design philosophy of F.A. Porsche clearly emerges in this collection that integrates technological materials and minimal design. The Porsche approach to develop innovative products starts with forms that are more integral to their intended functions.

The combination of functional, and minimal design with technological innovations is what makes the F.A. Porsche collection a timeless classic.

DESIGN by F.A. PORSCHE





EDO BLACK



EDONUDO



TSU BLACK



TSU BLACK



TSU



TSU



BLACK WASH



BLACK WASH



ONEIDA TSU



VERCINGE



BLACK POUF



COLOR BAR



TORIX BLACK

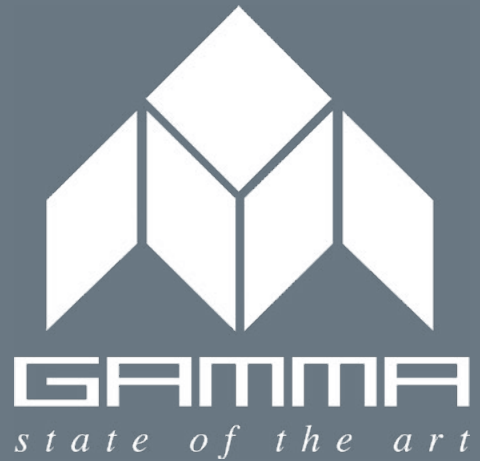

Transitional Design

GAMMA State of the Art propone un vasto assortimento di arredamenti di design e attrezzature per parrucchieri e saloni acconciatura, barbieri, spa e centri benessere.

Il catalogo include complementi e mobili a misura adatti per ogni salone, dal più grande al più piccolo.

Il brand raccoglie una vasta scelta di prodotti disegnati dal team di designer interno, che in collaborazione per studi di design esterni e l'ufficio di ricerca e sviluppo interno, hanno saputo trovare soluzioni capaci di combinare design e funzionalità.

GAMMA State of the Art offers a wide range of design furniture and equipment for hair salons, beauty salons, barbers, spas and wellness centers. The catalog includes custom cabinetry suitable for every salon, from the big to the small one.

The brand gathers a wide range of products designed by Gamma & Bross internal design team in collaboration with other design studios and the internal R&D department, to offer solutions able to combine design with functionality.



STYLING STATIONS POSTI DI LAVORO



HALO



ATMOSPHERE



LINK

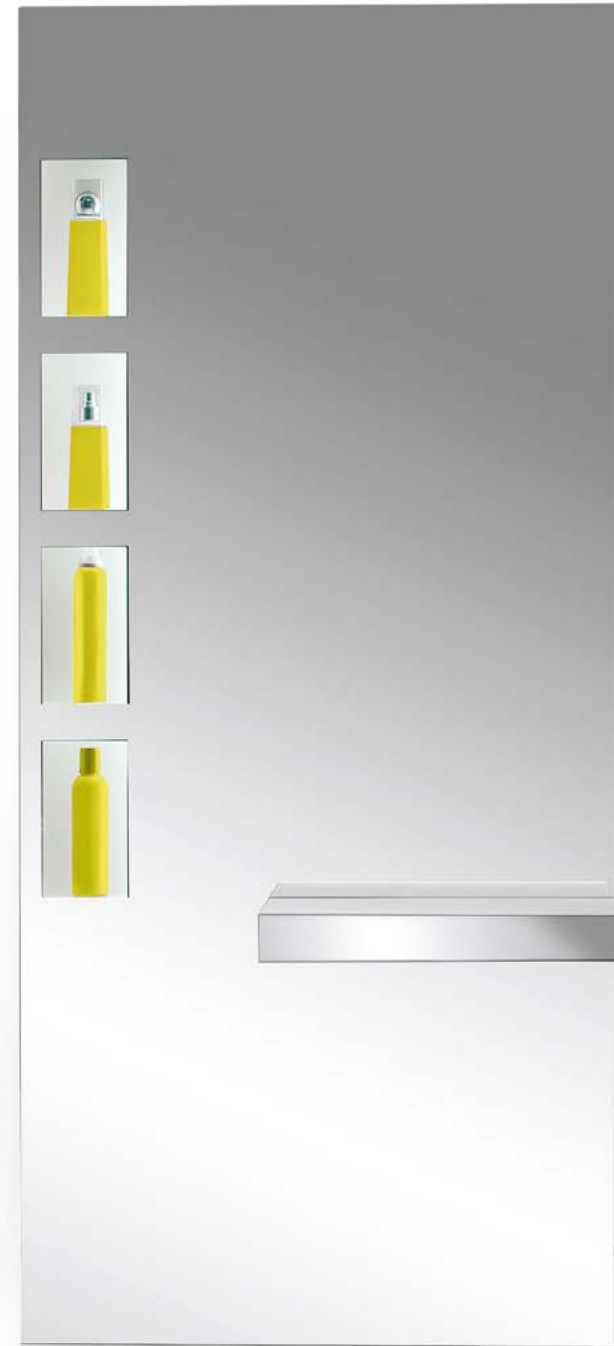

EXPERIENCE



REIKI



TIME² ISLAND



TRIPOD + SPECH



QUADRIPOD + BETELGEUSE DOUBLE MIRRORS



QUADRIPOD + SPECH MIRRORS



MONOBERT 2



DUOBERT 4



TRIOBERT 6



PARLOR ISLAND



POLARIS DIA



POLARIS 2



POLARIS 4.4



POLARIS 4.2



POLARIS 2.2



POLARIS 1



POLARIS CARRÉ 4.4



POLARIS CARRÉ 4.2



POLARIS CARRÉ 2.2



POLARIS CARRÉ 1



STYLING CHAIRS

POLTRONE ACCONCIATURA



AUREOLE



RIKKA



BUBBLE



FLOW CHAIR





MR RAY



MR RAY WMN



MR RAY SWAROVSKI



LOUIS 8





ACRILIA



DEMETRA



ONEIDA



NIKE



SKERAIOTIS



BLISS





CREUSA PLUG IN



CREUSA PLUG IN





PEGGYSUE MOVIBILE



PEGGYSUE



BASE MR RAY



BASE MAN RAY



BASE MARCEL WANDERS



BASE CROSS



BASE CROSS HOLLY



BASE SQUARE



BASE KARIM RASHID



BASE ROTO PEARL



BASE ROTO HOLLY



BASE STAR



BASE STAR HOLLY



BASE SQUARE HOLLY



BASE MALCOLM



TSU BASE



BASE TOTAL BLACK



BASE PARROT



BASE PARROT HOLLY



BASE PLUG IN



QUEEN MARY BASE GOLD



QUEEN MARY BASE BLACK



QUEEN MARY BASE CHROME



BASE TITAN



BASE SUPERGOLD



BASE SUPERBLACK

BASI

BASI



SHAMPOO STATIONS LAVAGGI



CELEBRITYWASH BASIC



CELEBRITYWASH SHIATSU



CELEBRITYWASH SOFA 2P



CELEBRITYWASH SOFA 3P



MORPHOWASH



MORPHOWASH 2P



VIP LOUNGE



VIP LOUNGE



DORMEUSE



WASHLONGUE 2011



WAITING AREA SOFAS DIVANI ATTESA



ISLAMORADA 190

ISLAMORADA POUF



PAPARAZZI



LOVE SEAT



HEBROS



BAGUA 2



BAGUA 1



SUNDIAL



ROTARY



ROUND TUFFET



RECEPTION DESKS BANCHI CASSA RECEPTION



MIDNIGHT DESK



SUNRISE DESK



FAT BEAUTY



MADAME DE POMPADOUR



COVENT GARDEN

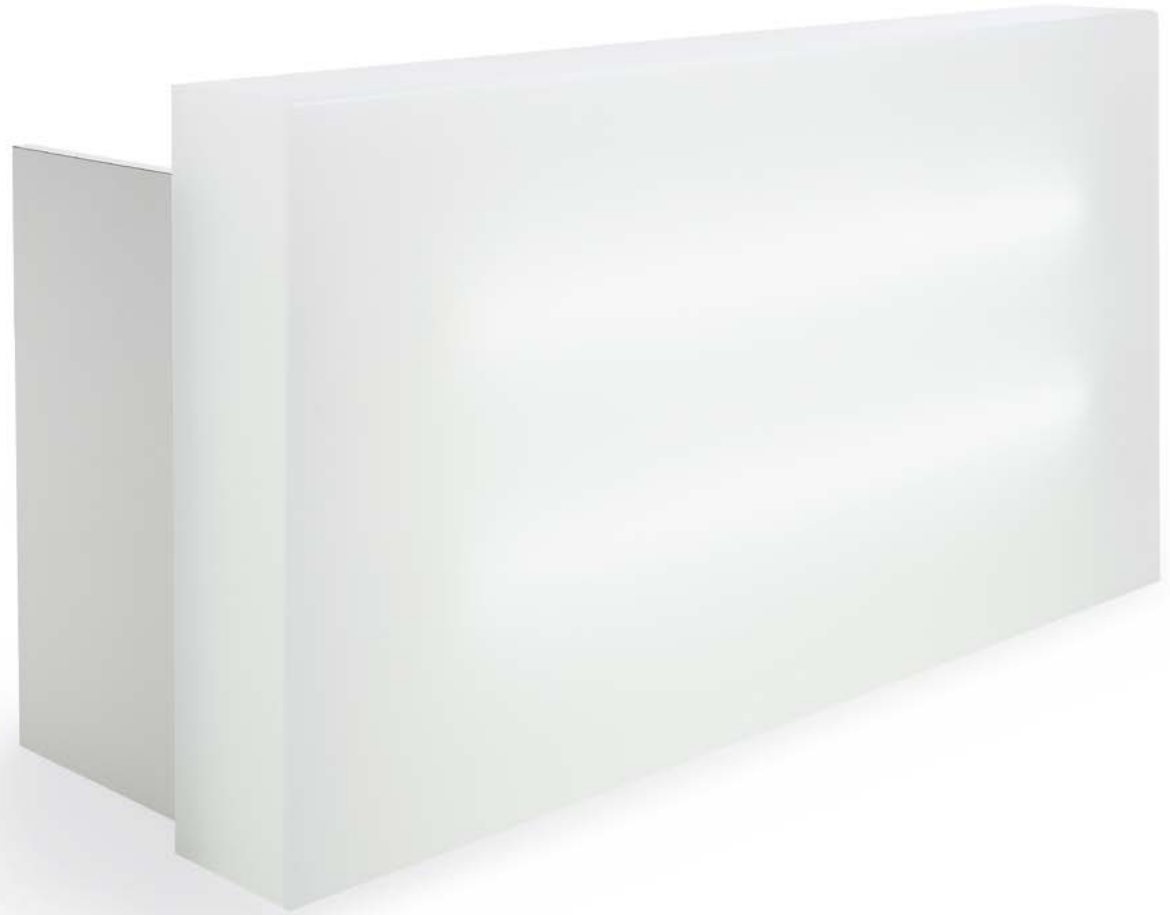

COVENT PLEX



RECEPTION DESK 1



RECEPTION DESK 2



RECEPTION DESK 2





CABINET SHOP è il sistema di mobili di servizio che permette di organizzare le aree di lavoro del vostro salone con grande flessibilità e stile. Le misure degli elementi consentono di combinare mobili e cassetti in una serie vastissima di soluzioni e le diverse opzioni e dimensioni disponibili permettono un'ampia scelta di stili. **CABINET SHOP** è prodotto interamente in Italia con tecnologie avanzate per ottenere giunzioni invisibili e una qualità dal taglio sartoriale.

CABINET SHOP is a line of furniture that allows you to organize the work area of your beauty salon with great flexibility and style. The size of the elements lets you combine cabinets and drawers in a wide range of solutions while the different options and sizes allow a wide choice of styles. **CABINET SHOP** is entirely manufactured in Italy using advanced technology to obtain seamless joints and tailored finishes.

CABINET SHOP est un système de meubles de service qui vous permet d'organiser au mieux les zones de travail de votre salon de façon très flexible et stylée. Les dimensions des éléments permettent d'assortir les meubles et les tiroirs en une série très vaste de solutions et les différentes options et mesures disponibles offrent un ample choix de styles. **CABINET SHOP** est entièrement produit en Italie grâce à des technologies à l'avant-garde pour obtenir des jointures invisibles et une qualité de coupe digne d'un couturier.

CABINET SHOP ist eine Möbel Linie, die es ermöglicht, Ihren Beauty Salon mit Flexibilität und und Stil zu organisieren. Aufgrund der großen Auswahl und Möglichkeiten, ist es möglich, vielfältige Kombinationen zu erzielen und mit seinem eigenen Stil zu verbinden. **CABINET SHOP** wird ausschließlich in Italien produziert. Fortschrittliche Technologien schaffen nahtlose Verbindungen und Veredelung der Produkte.

CABINET SHOP es el sistema del muebles de servicio que permite organizar las áreas de trabajo de su salon con gran flexibilidad y estilo. Las medidas de los elementos permiten combinar muebles y cajones en una amplia gama de soluciones y las diferentes opciones y tamaños disponibles ofrecen una amplia variedad de estilos. **CABINET SHOP** es una linea fabricada integramente en Italia con tecnologías avanzadas para lograr juntas invisibles con un resultado optimo, de mueble fabricado a medida.

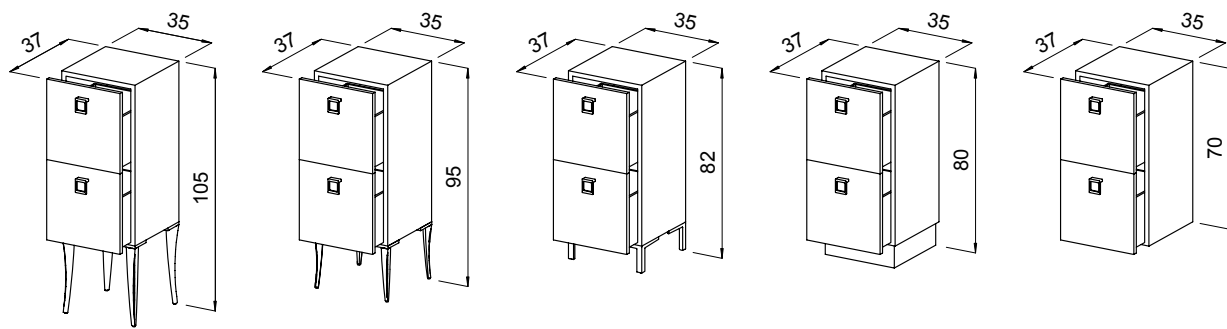

GG105

GG95

GG82

GG80

GG70

COLORS



Black



White



Wood

CABINET SHOP

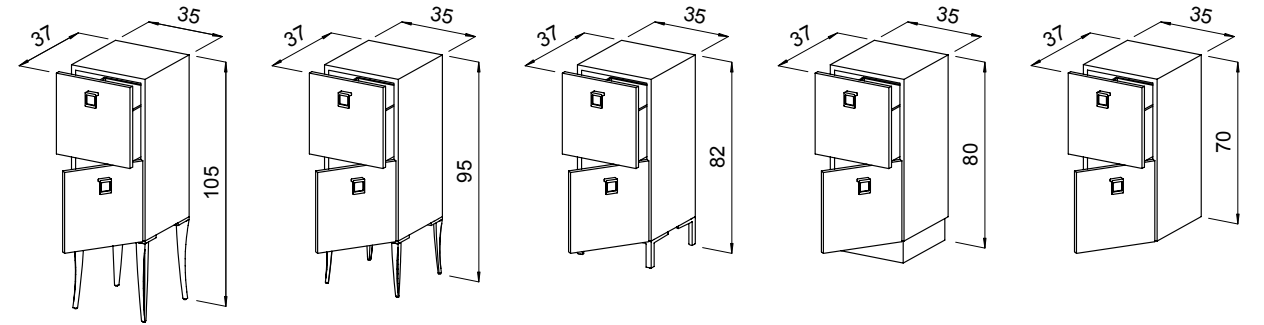

GA105

GA95

GA82

GA80

GA70

COLORS



Black



White



Wood

CABINET SHOP

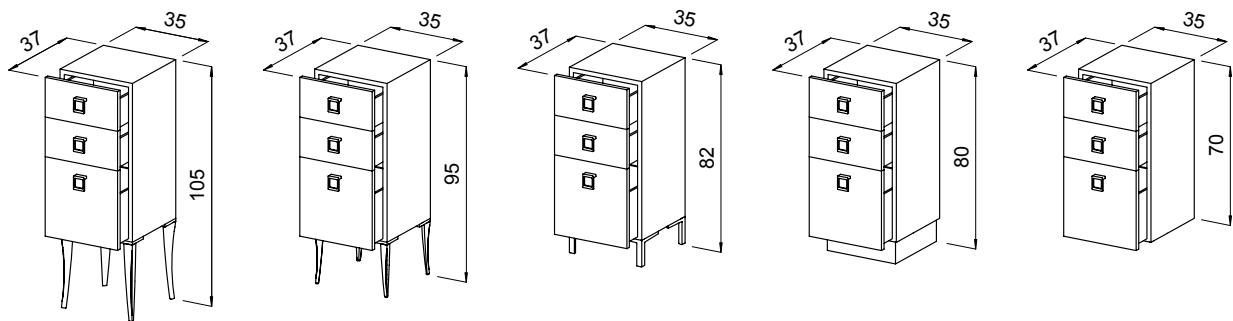

PPG105

PPG95

PPG82

PPG80

PPG70

COLORS



Black



White



Wood

CABINET SHOP

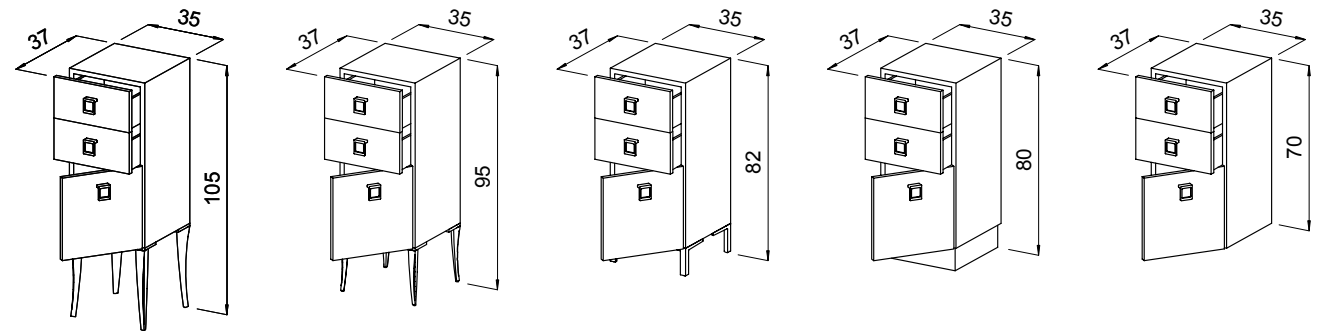

PPA105

PPA95

PPA82

PPA80

PPA70

COLORS



Black



White



Wood

CABINET SHOP

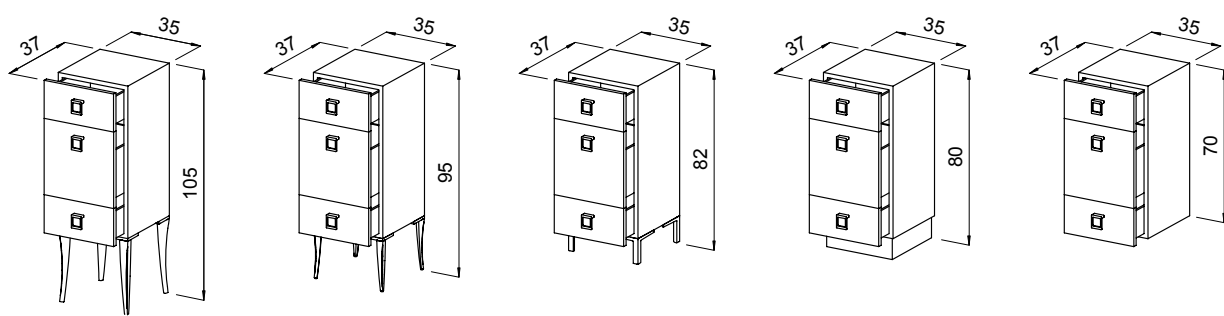

PGP105 PGP95 PGP82 PGP80 PGP70

COLORS  Black  White  Wood

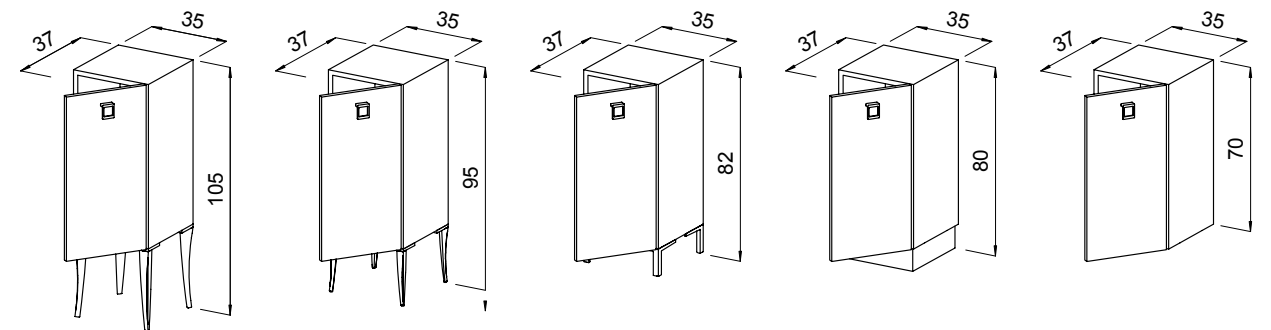

A105 A95 A82 A80 A70

COLORS  Black  White  Wood

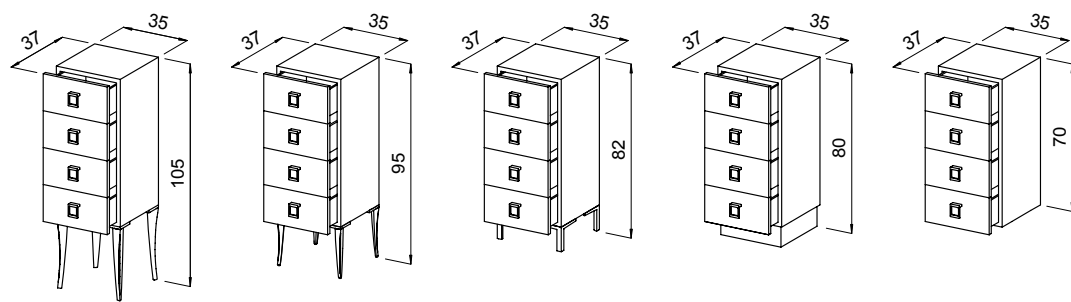

4P105

4P95

4P82

4P80

4P70

COLORS



Black



White



Wood

CABINET SHOP

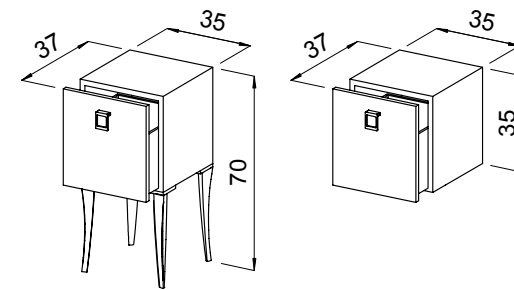

GLEG

GSUS

COLORS



Black



White



Wood

CABINET SHOP

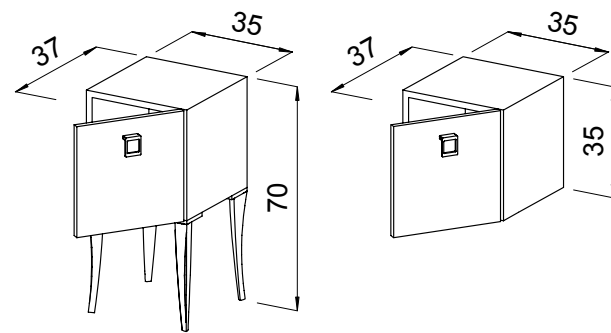

ALEG

ASUS

COLORS



Black



White



Wood

CABINET SHOP

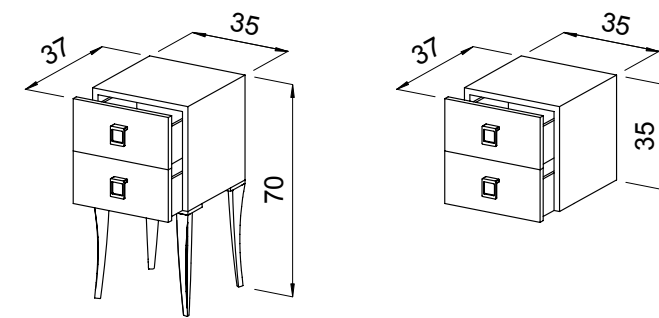

2PLEG

2PSUS

COLORS



Black



White



Wood

CABINET SHOP

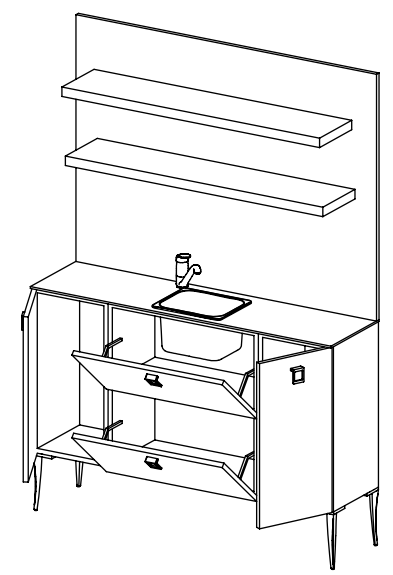
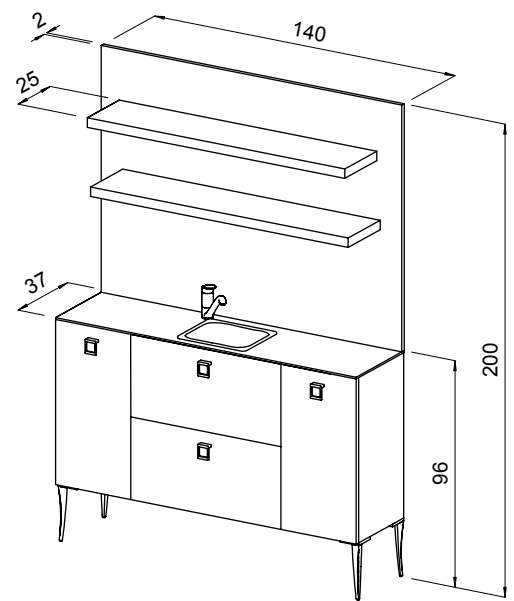
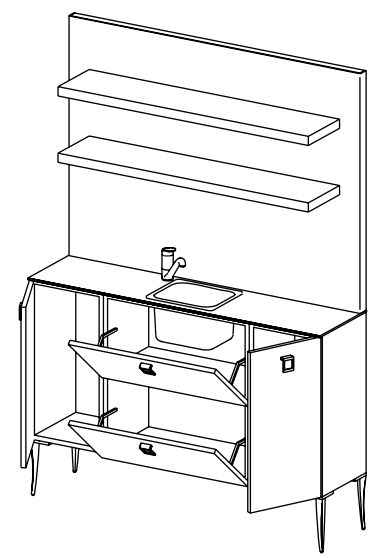
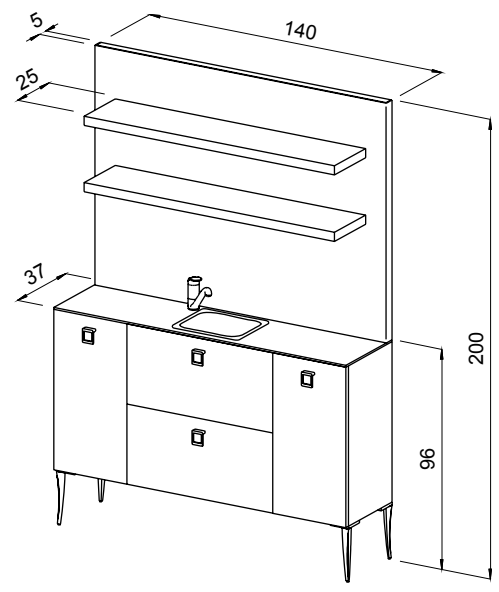



COLORS  Black  White

DLAB LIGHT

COLORS  Black  White

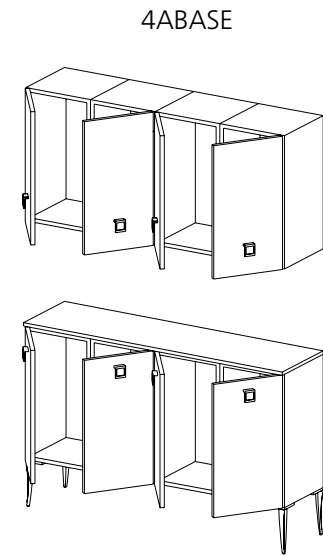
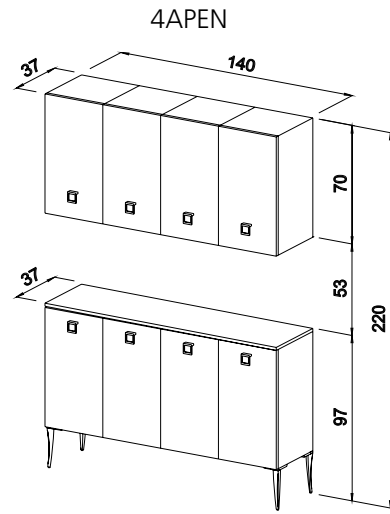
DLAB



COLORS  Black  White  Wood

4APEN / 4ABASE

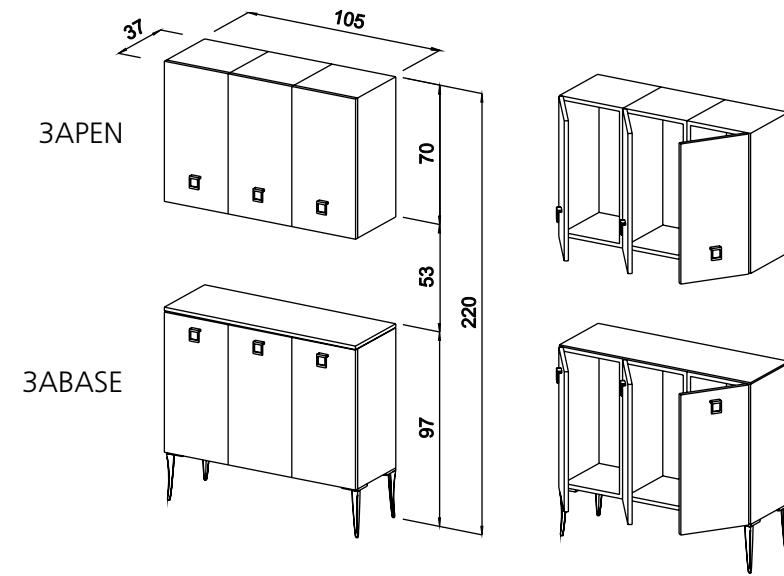

COLORS  Black  White  Wood

3APEN / 3ABASE

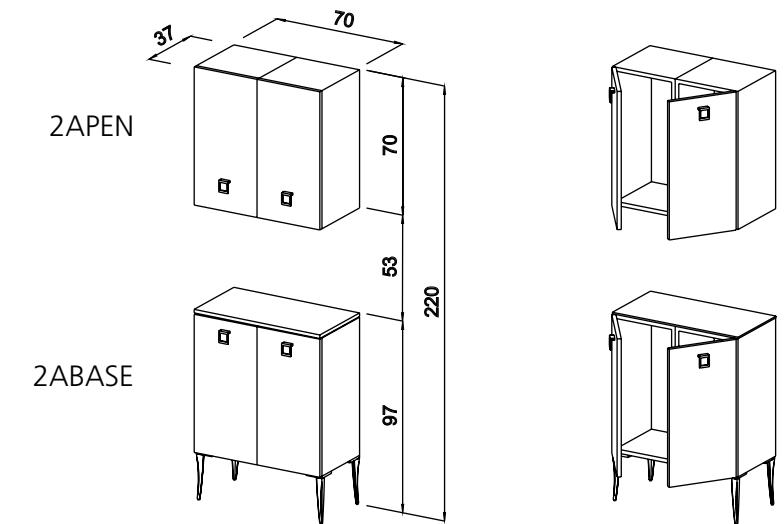

COLORS  Black  White  Wood

2APEN / 2ABASE



BACKSYSTEM 170



BACK VANI



BACK SERVICE



ACCRA TRI



ACCRA



DADA



CABINET 73



iCART



TAIKI



IBOX



CUBE



OPALE

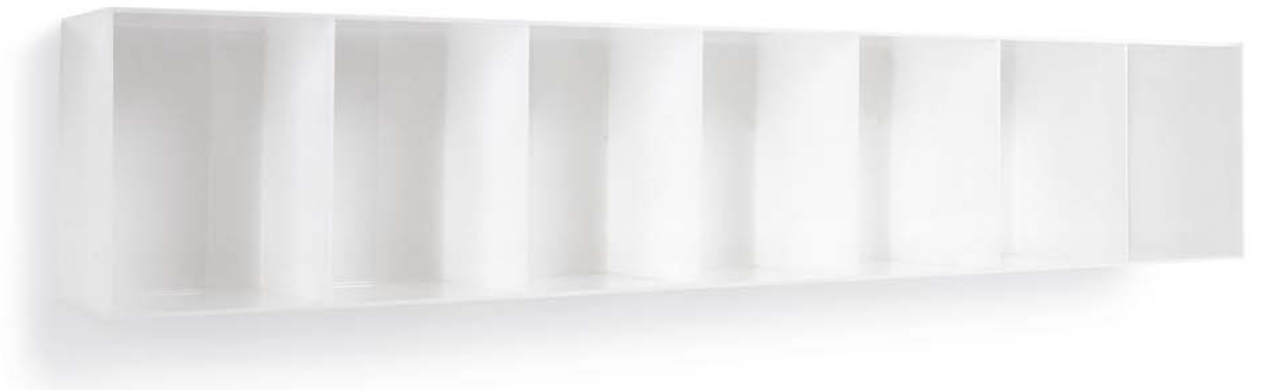

180



60



90

OPALE WALL



GLOWALL DISPLAY



GLOW ISLAND DISPLAY



2D4M



5D5B2M94M61L



DISPLAY





GONDOLA



TRIPLET 1



TRIPLET 2



TRIPLET 3



WINDOW 1

WINDOW 2



WINDOW 3

WINDOW 4

WINDOW 5



FLAMINGO 1

FLAMINGO 2



FLAMINGO 3



FOLDINO



JUNIOR



OKUMI CUT



PEDRO



PORTABORSE AC



BAGBOY



ONEIDA CUT



KELA PORTAPHON



KELA C PORTAPHON



BELFLOWER



BELFLOWER

BARBER SHOP



PRIMUM
VINTAGE
Barber
SHOP



BACK IN BLACK



POSTO DI LAVORO SRV



LENNY



LENNY



LENNY PLUG IN



LENNY PLUG IN



MR FANTASY



MR FANTASY ECO





GAMMASTORE

Il Design accessibile

GammaStore offre arredi e attrezzature per parrucchieri e saloni acconciatura a prezzi ragionevoli.

La qualità del Made in Italy non è mai stata così accessibile. Ogni anno Gamma & Bross presenta le nuove collezioni GammaStore in promozione, con la volontà di offrire linee di prodotto "Made in Italy" di alta qualità e design a prezzi estremamente contenuti.

Sin dall'inizio ci siamo posti una regola ferrea, una legge: "Si produce solo nel nostro territorio ad ogni costo e senza eccezioni, solo così si matura professionalità ed eccellenza." L'entusiasmo e la motivazione dei nostri collaboratori dipendono da questa regola e dalla certezza di aver contribuito alla realizzazione di un sogno che gli italiani da sempre hanno coltivato attraverso la costruzione di prodotti di prestigio.

***GammaStore** offers furnishings and equipment for hair shops and salons at reasonable pricing. Made in Italy quality has never been so affordable. Every year Gamma & Bross introduces new GammaStore collections on promotion, with the will to offer authentic "Made in Italy" product lines, with high quality and design at a very low price.*

From the beginning we hold firm to one rule: "To produce domestically no matter the cost, without exception", that is the only way to control quality, detail and mature excellence and professionalism."

The enthusiasm and motivation of our team depend on this rule and by the certainty to have contributed to the realization of a dream that Italians have always attained through the production of prestigious products.



STYLING STATIONS
POSTI LAVORO



TIMEGATE



PANDORA





PANDORA LED



PANDORA WALL LED



PROVOCATEUR E LEVEL



PROVOCATEUR BAR



JADMAHAL



JADMAHAL



BETELGEUSE



BETELGEUSE WALL



MADISON GOLD INFINITE 3P



MADISON GOLD INFINITE 2P



MADISON 1

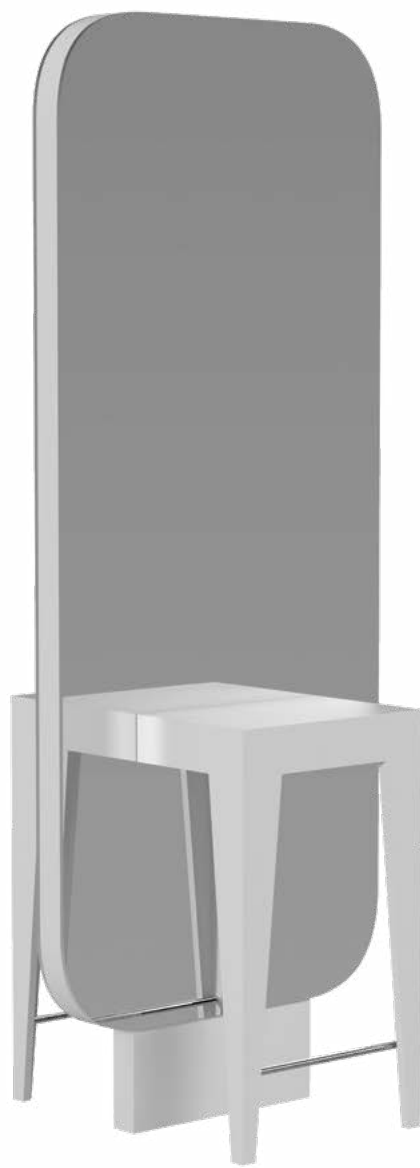

MADISON DOUBLE



MADISON ROUND



MADISON INFINITE 2P



MADISON INFINITE 3P



JADBAR ROUND MIRROR



JADBAR RECTANGULAR MIRROR





ECO



LUCE



ACTION



ALIFAX



ALIFAX CENTRALE

STYLING CHAIRS POLTRONE ACCONCIATURA

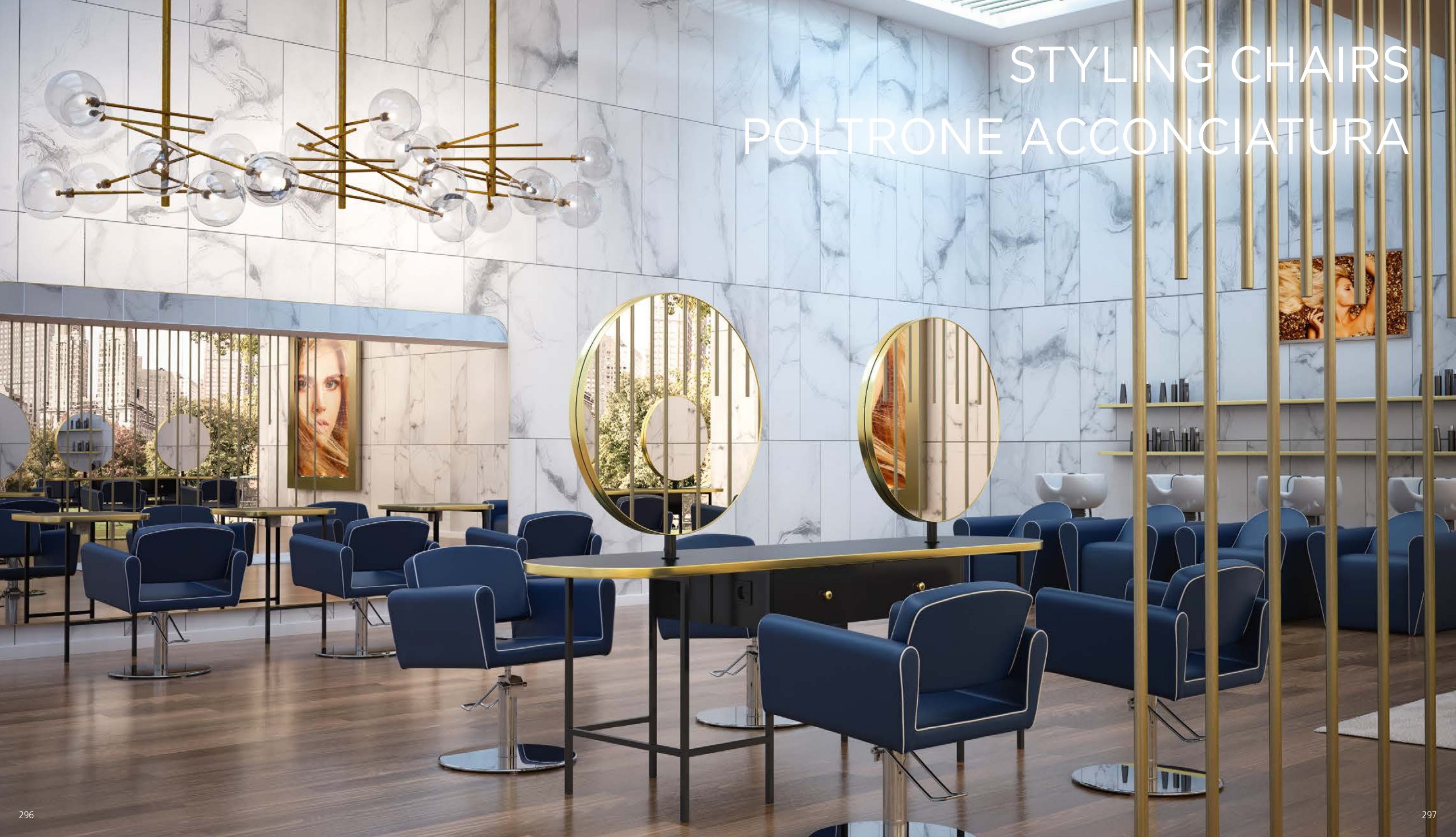



BLUESCHAIR ROTO



BLUES MAKE UP





AUREOLE ANNIVERSARY SUPERBLACK



RIKKA ANNIVERSARY SUPERBLACK



BIRKIN ROTO



CLUST SUPERGOLD



FIFTIES PARROT



FIFTIES ROTO



OLMA CPT ROTO



OLMA CPT PARROT



OLMA ROTO



OLMA PARROT



CREUSA ROTO



ALIPES ROTO



U-SHAPE ROTO



U-SHAPE QUILT SUPERBLACK



CLARA ROTO



CLARA PARROT



KUBIKA ROTO



ALUOTIS ROTO



DOLLCHAIR' (Poltrona didattica). Gamma&bross presenta DOLLCHAIR' , la prima poltrona brevettata specificamente indirizzata al training scolastico. DOLLCHAIR' dispone di un sistema a scomparsa che elimina e sostituisce il tradizionale supporto per testine integrandolo all'interno dello schienale della poltrona. DOLLCHAIR' è estremamente pratica e di facile uso , rende infatti il lavoro dello studente strettamente reale grazie alla posizione della testina che simula il cliente seduto sulla poltrona. L'utilizzatore è in grado di lavorare proprio come se fosse con un cliente reale , con la possibilità ulteriore di regolare in altezza la poltrona. DOLLCHAIR' permette inoltre di riporre direttamente all'interno dello schienale della poltrona il perno di sostegno della testina per un utilizzo tradizionale della poltrona , evitando tutte quelle operazioni di smontaggio e rimontaggio delle apparecchiature attualmente in commercio. DOLLCHAIR' è costruita interamente in Italia con materiali di alta qualità.

DOLLCHAIR' (Teaching chair). Gamma&Bross presents DOLLCHAIR' , the first patented chair specifically designed for school training. DOLLCHAIR' has a retractable system that eliminates and replaces the traditional heads-support for integrating it into the backrest of the chair. DOLLCHAIR' is extremely practical and easy to use; it makes the students experience very realistic thanks to the position of the head that simulates the customer sitting on the chair. With the additional possibility to adjust the height of the chair, the user is able to work just as if he or she were with a real client, DOLLCHAIR' also allows to put the head support directly inside the backrest of the chair for a traditional use, avoiding annoying assembly operations typical of the equipment currently on the market. DOLLCHAIR' is "Made in Italy" with high quality materials.

DOLLCHAIR' (Ausbildungsstuhl). Gamma&Bross präsentiert DOLLCHAIR®. Es ist der erste Stuhl, der speziell für die Schulausbildung entwickelt wurde. DOLLCHAIR® verfügt über eine versenkbare Kopfhalterung, die die traditionellen Halterungen ersetzt. Die Halterung lässt sich komplett in der Rückenlehne versenken. DOLLCHAIR® ist extrem praktisch und einfach zu bedienen. Die Schüler können somit sehr bequem am „Kopf“ arbeiten und die zusätzliche Höhenverstellung des Stuhles und die traditionelle Anbringung der Halterung, in der Rückenlehne, vermittelt einen realistischen Eindruck. Außerdem erspart sich der Anwender lästige Montagearbeiten, die bei anderen Stühlen obligatorisch waren. DOLLCHAIR® wird aus hochwertigen Materialien hergestellt und ist „Made in Italy“.

DOLLCHAIR

DOLLCHAIR' (Fauteuil didactique). Gamma&Bross présente DOLLCHAIR' , le premier fauteuil breveté adressé spécifiquement à la formation scolaire. DOLLCHAIR' dispose d'un système rétractile qui élimine et remplace le support pour têtes traditionnel en l'intégrant dans le dossier du fauteuil. DOLLCHAIR' est extrêmement pratique et facile à utiliser, il rend le travail de l'étudiant très réaliste grâce à la position de la tête qui simule le client assis dans le fauteuil. L'utilisateur est en mesure de travailler comme s'il était avec un vrai client, avec la possibilité supplémentaire de régler la hauteur du fauteuil. DOLLCHAIR' permet également de placer la broche de support de la tête directement dans le dossier du fauteuil, pour une utilisation traditionnelle du fauteuil, en évitant toutes les opérations de démontage et de remontage des équipements actuellement sur le marché. DOLLCHAIR' est construit entièrement en Italie avec des matériaux de haute qualité.

DOLLCHAIR' (Sillón didáctico). Gamma&Bross presenta DOLLCHAIR' , la primera silla patentada y dirigida específicamente para la formación de escuelas. DOLLCHAIR' cuenta con un sistema retráctil que elimina y reemplaza el soporte tradicional para cabezas, integrando-lo en el respaldo de la silla. DOLLCHAIR' es extremadamente práctico y fácil de usar. Hace que el trabajo de los estudiantes sea muy realista: gracias a la posición de la cabeza, que simula el cliente sentado en el sillón, el usuario es capaz de trabajar como si estuviera con el cliente real, con la posibilidad adicional de ajustar la altura de la butaca. DOLLCHAIR' también permite guardar el pasador del soporte de la cabeza directamente en el respaldo del sillón para un uso tradicional de la silla, evitando todas las operaciones de desmontaje y montaje típicas de todos los equipos actualmente disponibles en el mercado. DOLLCHAIR' está fabricado con materiales de alta calidad, en Italia.



ESCUELA

SHAMPOO STATIONS LAVAGGI





MUU MUU ECO



ULTRAWASH



MAMBOWASH



MAMBOWASH 2P



PRIVACY WASH



PRIVACY WASH



61 cm

FLATIRON





ULTRAWASH BLACK



ULTRAWASH Q CHROME



BLUESWASH



ULTRAWASH Q



ULTRAWASH UP





CLUBWASH



CELEBRITY ANNIVERSARY



CELEBRITY PRIME



CELEBRITY PRIME SOFA



GRALUOTIS ECOBLACK



GRALIWASH



KUBIKWASH



KUBISLED



WASH INN - ALUOTIS



WASH INN - ECOBLACK

WAITING AREA SEATING DIVANI ATTESA

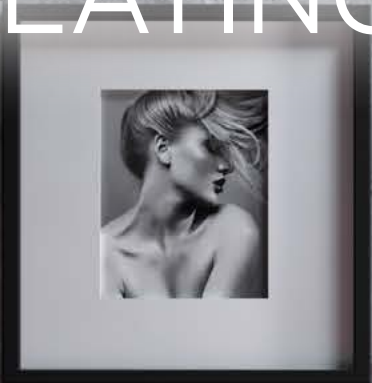



SLOOP



BEAN



KUBIBENCH



KUBICHAIR



BUBU



BUBU 2



4 EVER



4 EVER 2



BIRKIN SOFA



BIRKIN SOFA 2

SALON RECEPTION DESKS BANCHI CASSA RECEPTION





CPT DESK 150



CPT DESK 90





MADISON DESK 120



MADISON DESK 60



STATUS DESK 150 / 90 / 60



JADESK





SLEDESK



VELVET



YUKA



ECOCHIC



ACCESSORIES
ACCESSORI



JADORE 1



JADORE 2



TWIST



SUMI



DUETTO



SOFTCOL





GARI



WALLY



SPECH



spalogic

the architecture of wellness



STREAMLINE DECK



MANICURE PAD OPTIONAL



STREAMLINE BASIC



STREAMLINE
BASIC PIPELESS CHROME



HYDROLOUNGE





HYDROCART



HYDOSINK 1 e 2



ONEIDA STREAM



OKUMI STREAM



MONOLITH MAC

MONOLITHWASH



SOFT SURF



SQUARE SURF



BASICURE



FLEX



RALLY



COMMUTER



GLOSS



GLOSS





SPALAB



ZENLAB



ARTFORM



ARTFORM STORE



SPA LOUNGE



CELEBRITY RELAX



TEKNO RELAX



NIKE GLOSS

GAMMA & ROSS
SALON AND SPA DESIGN

RIVESTIMENTI • SAMPLES BOOK • REVÊTEMENTS • BESCHICHTUNGEN • MUESTRAS

Le finiture e i colori sono indicativi e possono subire variazioni dovute alla tecnica di stampa e alla visualizzazione su monitor. La società si riserva il diritto di modificare l'assortimento dei materiali senza preavviso.

The finishes and colors are indicative and may undergo variations due to the printing technique and display on the monitor. The company reserves the right to change the assortment of materials without notice.

Les finitions et les couleurs sont indicatives et peuvent subir des variations en fonction de la technique d'impression et de la visualisation à l'écran. Notre société se réserve le droit de modifier le choix des matériaux sans préavis.

Los acabados y colores son orientativos y pueden sufrir variaciones debido a la técnica de impresión y visualización en el monitor. La empresa se reserva el derecho de cambiar el surtido de materiales sin previo aviso.

Die Oberflächen und Farben sind Richtwerte und können aufgrund der Drucktechnik und der Anzeige auf dem Monitor variieren. Das Unternehmen behält sich das Recht vor, das Materialsortiment ohne vorherige Ankündigung zu ändern.

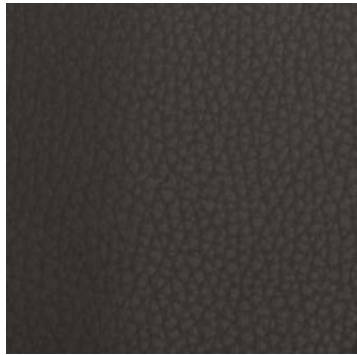

GUN NERO
CAT. A * X

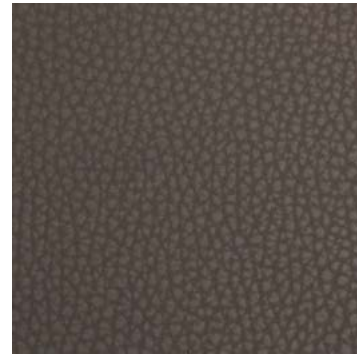

GUN METAL
CAT. A * X

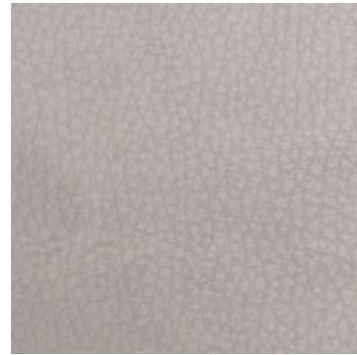

GUN GRIGIO
CAT. A * X



KIRSKE
CAT. B * X ⊕



OCEAN
CAT. B * X ⊕



YUTA GREY
CAT. A * X



GUN OTTANIO
CAT. A * X



GUN ROSSO
CAT. A * X



GUN BEIGE
CAT. A * X



YUTA BRUN
CAT. A * X

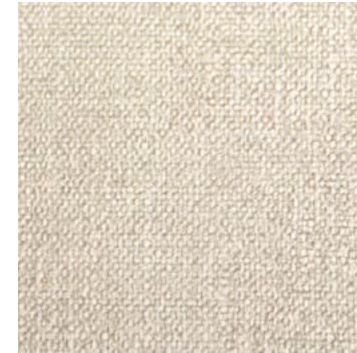

YUTA
CAT. A * X



MOKA
CAT. B * X ⊕



GUN MUD
CAT. A * X

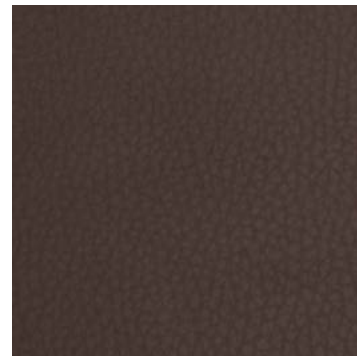

GUN MORO
CAT. A * X



IVORY
CAT. B * X ⊕



XENOX NERO
CAT. B *

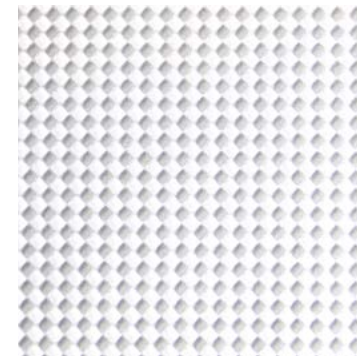

DIAGO ARGENTO
CAT. B *

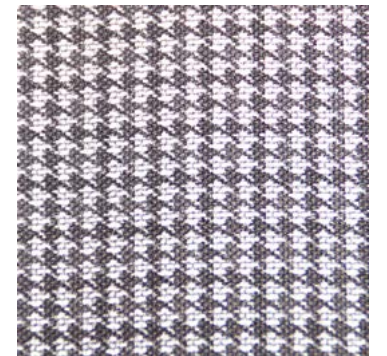

PIED DE POULE
CAT. B

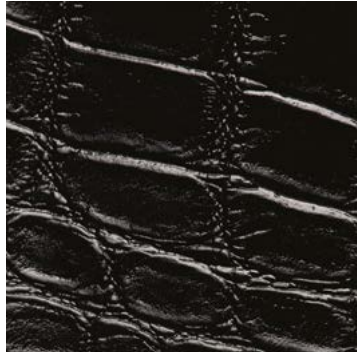

CROCONERO
CAT. B



CIPRIA
CAT. A *



FOREST
CAT. A * X



GRIGIOMEDIO 28
CAT. Z * X



VERDE 97
CAT. Z * X



ROSSO 16
CAT. Z * X



N001
CAT. A *

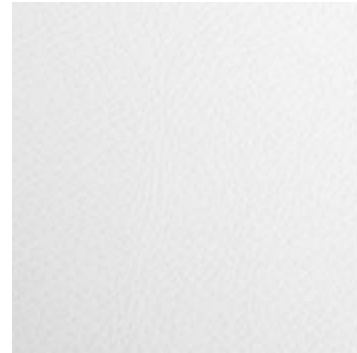

BLANC
CAT. A * X



NERO 42
CAT. Z * X



BORDEAUX 19
CAT. Z *



GRIGIO 31
CAT. A * X

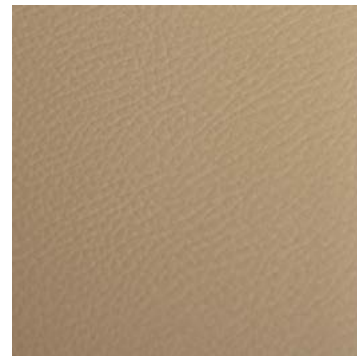

ALPACA 09
CAT. Z * X



SABBIA 02
CAT. Z * X

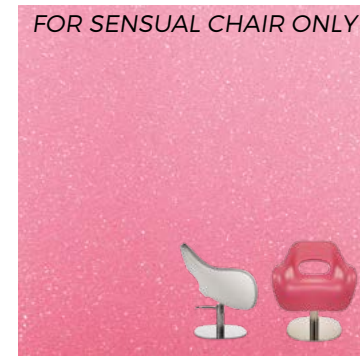

FOR SENSUAL CHAIR ONLY

K.R. PINK
CAT. B



FOR SENSUAL CHAIR ONLY

K.R. METAL
CAT. B



FOR SENSUAL CHAIR ONLY

K.R. BLACK
CAT. B



IVORY QUILT
CAT. B



MOKA QUILT
CAT. B



NERO QUILT
CAT. B



AMALFI 76

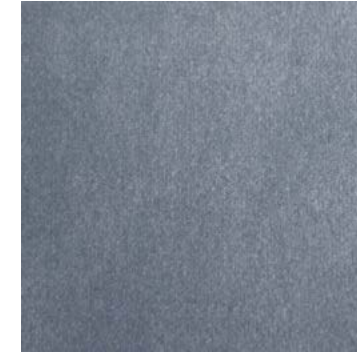

ARTIC 55

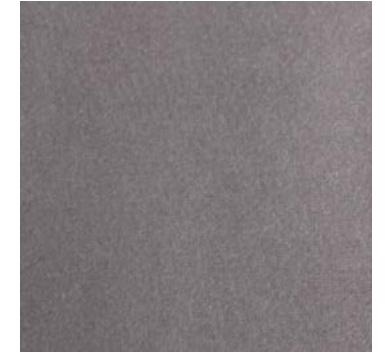

SEAL 4

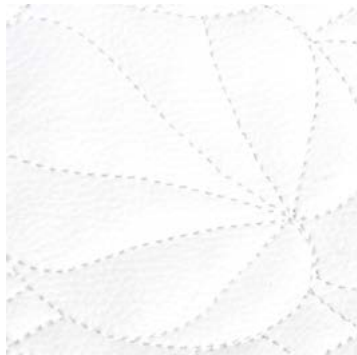

LOTUS BLANC
CAT. B



LOTUS GUN NERO
CAT. B



LOTUS CIPRIA
CAT. B



SAND 51



FLAMINGO 56



RUBY 30



NERO CPT
CAT. B

- ◆ LOGHI STAMPATI O RICAMATI SU RICHIESTA
- ◆ PRINTED OR EMBROIDERED LOGOS UPON REQUEST
- ◆ LOGOS IMPRIMÉS OU COUSUS SUR DEMANDE
- ◆ GEDRUCKTE ODER GESTICKTE LOGOS AUF ANFRAGE
- ◆ LOGOTIPOS IMPRESOS O BORDADOS BAJO PEDIDO



WINE 57

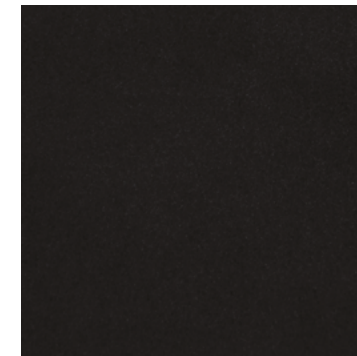

BLACK 32



MUSKIO 37

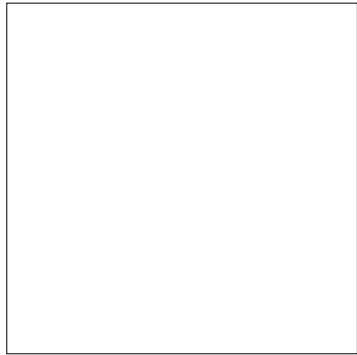

BIANCO 003



U 508



U 007 NERO



BIANCO

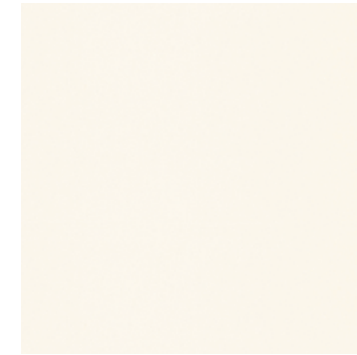

AVORIO



CAPPUCCINO



MAGNOLIA 810



OLMO LAVA

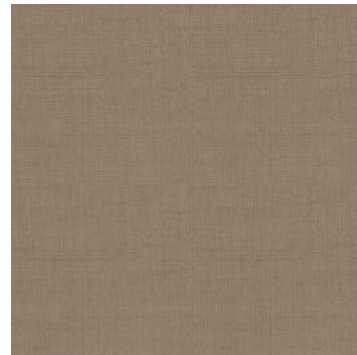

CONFORT 42

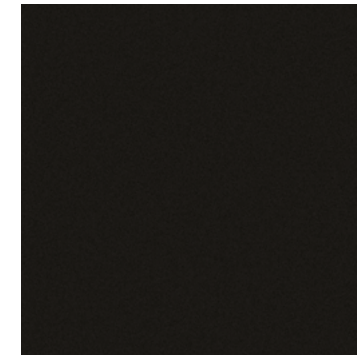

NERO



ROSSO



OLMO CANNELLA

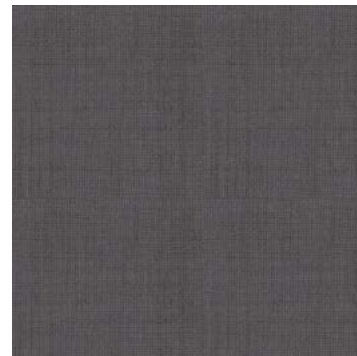

MYSTERY 48

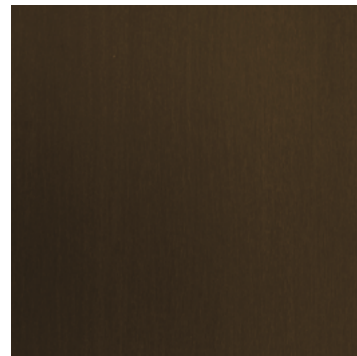

WENGÈ

FRAME PROFILES FOR BETELGEUSE



NERO



ORO

 = IGNIFUGO • FLAME RETARDANT • IGNIFUGE • MATERIAL FEUERFEST • MATERIAL IGNÍFUGO

 = VALIDO SOLO • VALID ONLY • VALABLE POUR • NUR GÜLTIG • VÁLIDO POR

Europa.eu

 EN1021 - 1+2

Italy 

 UNI 9175/87 CLASS 1.1M

Austria

 ÖNORM A 3800-1 - ÖNORM B 3825

France, Belgium, Luxembourg

 NF P 92501-7 CLASS M1-M2-M3

Great Britain 

 BS5852 IS-0+1+5

Germany

 EN1021 - 1+2

North America 

 MVSS302 CALIFORNIA TB 116

 IMO res. MSC.307 (88) - (2010 FPT) Annex 1 Part 8

I nostri nobilitati e laminati rispettano i seguenti Standard Internazionali

Our melamine and laminate finish comply with the following International Standards

Nos stratifiés et mélaminés respectent les standards Internationaux Suivants

Unsere Holz und Kunststoffplatte Schichstoffplatte entsprechen den folgenden Internationalen Standards

Nuestros melaminico y laminados cumplen con los siguientes Estándares Internacionales



NORMATIVE • REGULATIONS • NORMES • VORSCHRIFTEN • NORMATIVA

SKAI/ VINYL/ SKAYBEZUG	EUROPE	GERMANY	FRANCE, BELGIUM, LUXEMBOURG	AUSTRIA	ITALY	USA - CANADA	GREAT BRITAIN	IMO res. MSC.307 (88) (2010 FPT) Annex 1 Part 8
	EN1021 - 1+2	EN1021 - 1+2	NF P 92501-7 CLASS M1-M2-M3	ÖNORM A 3800-1 ÖNORM B 3825	UNI 9175/87 CLASS 1.1M	MVSS302 CALIFORNIA TB 116	BS5852 IS-0+1+5	
ALPACA 09								
BLANC					✓	✓	✓	
BORDEAUX 19					✓	✓	✓	
CIPRIA		✓			✓	✓	✓	
CROCONERO					✓		✓	
DIAGO ARGENTO								
FOREST	✓	✓	✓	✓	✓	✓	✓	✓
GRIGIO 31					✓	✓	✓	
GRIGIOMEDIO 28					✓	✓	✓	
GUN BEIGE					✓	✓	✓	
GUN GRIGIO					✓	✓	✓	
GUN METAL					✓	✓	✓	
GUN MORO					✓	✓	✓	
GUN MUD					✓	✓	✓	
GUN NERO					✓	✓	✓	
GUN OTTANIO					✓	✓	✓	
GUN ROSSO					✓	✓	✓	
IVORY	✓	✓	✓	✓	✓	✓	✓	✓
IVORY QUILT	✓	✓	✓	✓	✓	✓	✓	
K.R. BLACK								
K.R. METAL								
K.R. PINK								
KIRSKA	✓	✓	✓	✓	✓	✓	✓	✓
LOTUS BLANC					✓	✓	✓	
LOTUS CIPRIA					✓	✓	✓	
LOTUS GUN NERO					✓	✓	✓	
MOKA	✓	✓	✓	✓	✓	✓	✓	✓
MOKA QUILT	✓	✓	✓	✓	✓	✓	✓	✓
NO01					✓	✓	✓	
NERO 42					✓	✓	✓	
NERO CPT					✓	✓	✓	
NERO QUILT					✓	✓	✓	
OCEAN	✓	✓	✓	✓	✓	✓	✓	✓
PIED DE POULE		✓			✓	✓	✓	
ROSSO 16					✓	✓	✓	
SABBIA 02					✓	✓	✓	
VERDE 97					✓	✓	✓	
XENOX NERO								
YUTA					✓	✓	✓	
YUTA BRUN					✓	✓	✓	
YUTA GREY					✓	✓	✓	

LE INFORMAZIONI CONTENUTE IN QUESTO STAMPATO NON SONO VINCOLANTI.
GAMMA & BROSS SI RISERVA LA FACOLTÀ DI EFFETTUARE EVENTUALI MODIFICHE SENZA PREAVVISO.
I COLORI DEI PRODOTTI POSSONO NON RIPRODURRE FEDELMENTE QUELLI REALI.

THE PHOTOS OF THE PRODUCTS ARE INDICATIVE.
GAMMA & BROSS RESERVES THE RIGHT TO INTRODUCE CHANGES TO THE PRODUCTS WITHOUT NOTICE.
THE COLORS SHOWN IN THESE PICTURES MAY DIFFER FROM THE ACTUAL COLOR OF THE PRODUCTS.



GAMMA & BROSS s.p.a. via G. Mazzini 62 E - 46043 Castiglione d/Stiviere MN - Italy
tel. +39 0376 632630 - fax +39 0376 636683 - info@gammabross.com

GAMMA & BROSS USA INC. Industry City, 68 34th street, unit 7, 2nd floor, Brooklyn NY 11232 - U.S.A.
tel. (212) 239-6916 fax (212) 239-6917 - info@beautydesign.com - www.beautydesign.com

GAMMA & BROSS DEUTSCHLAND Halskestraße, 46, 40880 Ratingen
tel +49 177 793 67 28 - deutschland@gammabross.com

SHOWROOM PARIS GAMMA & BROSS FRANCE 4, Rue de Charenton 94140 Alfortville - France
tel. +33 01 43536868 - fax +33 01 43530669 - paris@gammabross.com



www.gammabross.com

www.mgbross.com

www.gammastore.com

www.spalogic.net

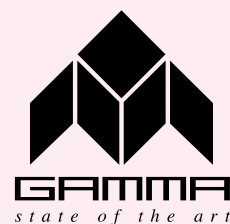

GAMMASTORE



Follow us on:



2022

